

# Stylage



Designer : Michel Tortel



## Style and performance for a new age

With its typical 4-faced design, the Stylage luminaire brings the classical style lanterns into the 21st century.

Thanks to its modern twist on a classic design, the Stylage urban luminaire easily blends into both historical city centres and areas with more contemporary architecture.

Stylage is the ideal tool to create aesthetic consistency in cities composed of a mixture of heritage and modern architecture and who wish to highlight their historical patrimony while accentuating their commitment to the future.

IP 66	IK 08	
	005 certification	CE



## Concept

Stylage is available in two versions: with a flat glass protector or with a polycarbonate protector. With an aluminium body, Stylage benefits from high-quality recyclable materials.

Equipped with the performing LensoFlex®2 LED engine, the Stylage luminaire offers high performance with energy savings that can exceed 75% compared to luminaires fitted with traditional light sources. This efficiency lowers its payback time and contributes to a responsible use of natural resources.

The large semi-sanded protector version of Stylage is available with an aluminium flame to emulate the gas-jet lamps of the last century. At night, this creates a decorative effect as when you approach the luminaire, the flame seems to flicker, due to the reflections on the aluminium surface.

Stylage is designed for post-top mounting on a Ø60mm or ¾" gas spigot. A suspended version with a 1" female or ¾" gas fixation is also available.



Stylage offers a neo-classical design



Stylage can be delivered with a pre-fitted electrical supply cable

## TYPES OF APPLICATION

- URBAN & RESIDENTIAL STREETS
- BRIDGES
- BIKE & PEDESTRIAN PATHS
- RAILWAY STATIONS & METROS
- CAR PARKS
- SQUARES & PEDESTRIAN AREAS

## KEY ADVANTAGES

- Elegant and comfortable solution for creating ambiance
- Available with a flat glass or a full protector in polycarbonate
- Energy savings of up to 75% compared with traditional light sources
- No light pollution: ULOR 0% in flat glass version
- Designed to incorporate the Owllet range of control solutions



The optical unit and the driver are enclosed in the top cover of the luminaire



Stylage is available for post-top or suspended mounting, with or without an aluminium flame



## LensoFlex®2

LensoFlex®2 is based upon the addition principle of photometric distribution. Each LED is associated with a specific PMMA lens that generates the complete photometric distribution of the luminaire. The number of LEDs in combination with the driving current determines the intensity level of the light distribution.

The proven LensoFlex®2 concept includes a glass protector to seal the LEDs and lenses into the luminaire body.



## Back Light control

As an option, the LensoFlex®2 and LensoFlex®4 modules can be equipped with a Back Light control system (figure B). This additional feature minimises light spill from the back of the luminaire to avoid intrusive light towards buildings.

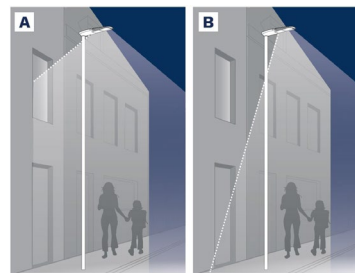

A. Without Back Light control | B. With Back Light control



### Custom dimming profile

Intelligent luminaire drivers can be programmed with complex dimming profiles. Up to five combinations of time intervals and light levels are possible. This feature does not require any extra wiring.

The period between switching on and switching off is used to activate the preset dimming profile. The customised dimming system generates maximum energy savings while respecting the required lighting levels and uniformity throughout the night.

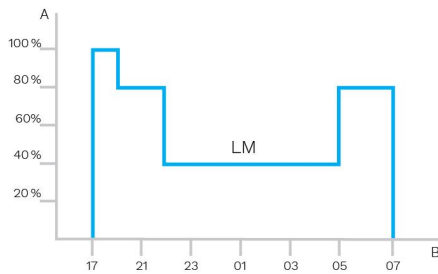

A. Performance | B. Time



### Daylight sensor / photocell

Photocell or daylight sensors switch the luminaire on as soon natural light falls to a certain level. It can be programmed to switch on during a storm, on a cloudy day (in critical areas) or only at nightfall so as to provide safety and comfort in public spaces.

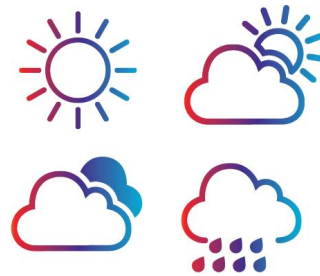

### PIR sensor: motion detection

In places with little nocturnal activity, lighting can be dimmed to a minimum most of the time. By using passive infrared (PIR) sensors, the level of light can be raised as soon as a pedestrian or a slow vehicle is detected in the area.

Each luminaire level can be configured individually with several parameters such as minimum and maximum light output, delay period and ON/OFF duration time. PIR sensors can be used in an autonomous or interoperable network.



## Owlet IoT

Owlet IoT remotely controls luminaires in a lighting network, creating opportunities for improved efficiency, accurate real-time data and energy savings of up to 85%.



### ALL-IN-ONE

The LUCO P7 CM controller includes the most advanced features for optimised asset management. It also provides an integrated photocell and operates with an astronomical clock for seasonal dimming profile adaptations.

### EASY TO DEPLOY

Thanks to wireless communication, no cabling is needed. The network is not subject to physical constraints or limitations. From a single control unit to an unlimited network, you can expand your lighting scheme at any time.

With real-time geolocation and automatic detection of luminaire features, commissioning is quick and easy.

### USER-FRIENDLY

Once a controller is installed on a luminaire, the luminaire automatically appears with its GPS coordinates on a web-based map.

An easy-to-use dashboard enables each user to organise and customise screens, statistics and reports. Users can gain relevant, real-time insights.

The Owlet IoT web application can be accessed at all times from anywhere in the world with a device connected to the Internet. The application adapts to the device to offer an intuitive and user-friendly experience.

Real-time notifications can be pre-programmed to monitor the most important elements of the lighting scheme.

### SECURE

The Owlet IoT system uses a local wireless mesh communication networks to control the on-site luminaires combined with a remote control system utilising the cloud to ensure smooth data transfers to and from the central management system.

The system uses encrypted IP V6 communication to protect data transmission in both directions. Using a secure APN, Owlet IoT ensures a high level of protection.

In the exceptional case of a communication failure, the built-in astronomical clock and photocell will take over to switch the luminaires on and off, thus avoiding a complete blackout at night.

### EFFICIENT

Thanks to sensors and/or pre-programmed settings, lighting scenarios can be easily adapted to cope with live events, providing the right lighting levels at the right time and in the right place.

The integrated utility grade meter offers the highest accuracy available on the market today, enabling decisions based on real figures.

Accurate real-time feedback and clear reporting ensures that the network operates efficiently and maintenance is optimised.

When LED luminaires are switched on, the inrush current can create problems for the electricity grid. Owlet IoT incorporates an algorithm to preserve the grid at all times.

### OPEN

The LUCO P7 CM controller can be plugged onto the standard 7 pin NEMA socket and operates through either a DALI or 1-10V interface to control the luminaire.

Owlet IoT is based on the IPv6 protocol. This method for addressing devices can generate an almost unlimited number of unique combinations to connect non-traditional components to the Internet or computer network.

Through open APIs, Owlet IoT can be integrated into existing or future global management systems.

The Schröder Bluetooth solution consists of 3 main components:

- A Bluetooth dongle plugged into the modular driver of the luminaire (BLE transceiver)
- A Bluetooth antenna fitted on the luminaire
- A smartphone application called Sirius BLE



## Easy to use

The Schröder Bluetooth solution is ideal for the on-site configuration of individual outdoor luminaires using Bluetooth. From the ground, the user is able to switch the luminaire on or off, adapt the dimming curve, read diagnostic data and much more. A user-friendly application called Sirius BLE provides an easy and secure access to the control and configuration functions.

Whether you are managing a lighting network in an urban or a residential area, this solution will make it easy to control your outdoor luminaires while simply standing by the pole.

## Quick and easy pairing

Get the Sirius App from Schröder. Go to the menu. Press the “SCAN DEVICE (START)” button, to search for the surrounding BLE modules. They will be displayed with a bar graphic (signal intensity) to indicate the closest and the most distant one you can reach. Click on the device you want to connect to and enter your personal access key to control the luminaire.

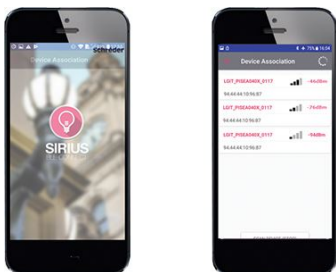

## Defining the settings

Once you are connected to a luminaire, you can set various parameters such as the maximum output current, minimum dimming level and custom dimming profile.

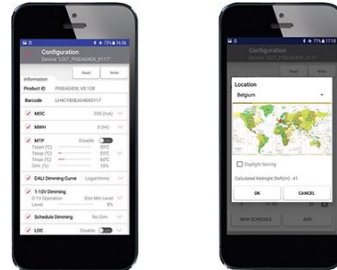

## Manual dimming control

The App enables you to do a manual override to adapt the dimming levels instantly. Simply tap on the “Dimming” button in the main menu and adjust the dimming using the wheel and button. Predefined dimming levels can be applied immediately. The corresponding value is displayed on the wheel. This enables you to test the ON / OFF and dimming features of the luminaire paired to the smartphone.



## On-site diagnostic

When a luminaire is paired, you can access various diagnostic information: total number of power up events, operation time of LED module and driver, total energy consumption of LED driver... etc. You can also track operating events (short circuits, thermal shutdowns...). The diagnostic values may be the current state or values accumulated to date.

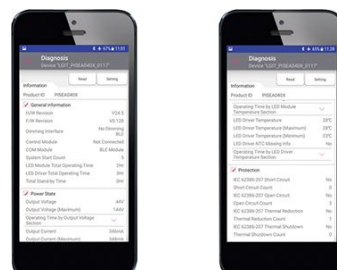

## GENERAL INFORMATION

Recommended installation height	3m to 5m   10' to 16'
FutureProof	Easy replacement of the photometric engine and electronic assembly on-site
Driver included	Yes
CE Mark	Yes
ENEC certified	Yes
ETL/UL certified	Yes
ROHS compliant	Yes
French law of December 27th 2018 - Compliant with application type(s)	a, b, c, d, e, f, g
BE 005 certified	Yes
Testing standard	LM 79-08 (all measurements in ISO17025 accredited laboratory)

## HOUSING AND FINISH

Housing	Aluminium
Optic	PMMA
Protector	Tempered glass Polycarbonate
Housing finish	Polyester powder coating
Standard colour(s)	AKZO grey 900 sanded
Tightness level	IP 66
Impact resistance	IK 08
Vibration test	Compliant with modified IEC 68-2-6 (0.5G)
Access for maintenance	Direct access to the gear compartment by loosening screws on the top cover

## OPERATING CONDITIONS

Operating temperature range (Ta)	-30 °C up to +35 °C / -22 °F up to 95°F
----------------------------------	---

· Depending on the luminaire configuration. For more details, please contact us.

## ELECTRICAL INFORMATION

Electrical class	Class I EU, Class II EU
Nominal voltage	220-240V – 50-60Hz
Power factor (at full load)	0.9
Surge protection options (kV)	10
Electromagnetic compatibility (EMC)	EN 55015 / EN 61000-3-2 / EN 61000-3-3 / EN 61547
Control protocol(s)	Bluetooth, 1-10V, DALI
Control options	AmpDim, Bi-power, Custom dimming profile, Photocell, Remote management
Socket	Low voltage socket (optional) NEMA 7-pin (optional)
Associated control system(s)	Sirius BLE Owlet Nightshift Owlet IoT
Sensor	PIR (optional)

## OPTICAL INFORMATION

LED colour temperature	2200K (Warm White 822) 2700K (Warm White 727) 3000K (Warm White 730) 3000K (Warm White 830) 4000K (Neutral White 740)
Colour rendering index (CRI)	>80 (Warm White 822) >70 (Warm White 727) >70 (Warm White 730) >80 (Warm White 830) >70 (Neutral White 740)
Upward Light Output Ratio (ULOR)	0%

· ULOR may be different according to the configuration. Please consult us.

## LIFETIME OF THE LEDS @ TQ 25°C

All configurations	100,000h - L90
--------------------	----------------

## DIMENSIONS AND MOUNTING

AxBxC (mm   inch)	373x705x373   14.7x27.8x14.7
Weight (kg   lbs)	8   17.6
Aerodynamic resistance (CxS)	0.11
Mounting possibilities	Post-top slip-over – Ø60mm Post-top ¾" gas male Suspended ¾" gas female Suspended 1" gas female

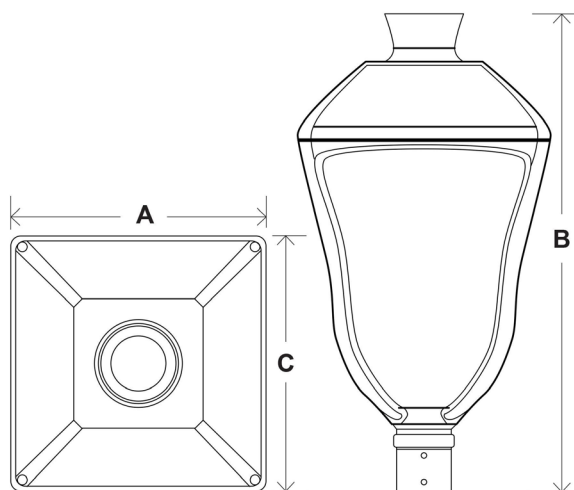





Luminaire	Number of LEDs	Current (mA)	Luminaire output flux (lm) Warm White 727		Luminaire output flux (lm) Warm White 730		Luminaire output flux (lm) Warm White 822		Luminaire output flux (lm) Warm White 830		Luminaire output flux (lm) Neutral White 740		Power consumption (W)		Luminaire efficacy (lm/W)	Photometry
			Min	Max	Min	Max	Min	Max	Min	Max	Min	Max	Min	Max		
STYLAGE	16	200	900	900	1000	1000	700	700	900	900	1000	1100	11.1	11.1	99	
	16	300	1400	1600	1600	1700	1100	1200	1400	1600	1700	1800	15.8	15.8	114	
	16	400	1900	2100	2200	2300	1500	1600	1900	2100	2200	2400	20.8	20.8	115	
	16	500	2300	2500	2600	2800	1800	2000	2300	2500	2700	2900	26.1	26.1	111	
	16	600	2600	2900	3000	3200	2100	2300	2600	2900	3100	3300	31.2	31.2	106	
	16	700	2900	3100	3200	3400	2300	2400	2900	3100	3300	3600	36.1	36.1	100	
	16	850	3000	3200	3300	3600	2400	2600	3000	3200	3500	3700	44	44	84	
	24	200	1300	1400	1500	1600	1000	1100	1300	1400	1500	1600	15.4	15.4	104	
	24	300	2200	2400	2400	2600	1700	1900	2200	2400	2500	2700	22.5	22.5	120	
	24	400	2900	3200	3300	3500	2300	2500	2900	3200	3400	3700	29.9	29.9	124	
	24	500	3500	3800	3900	4200	2800	3000	3500	3800	4100	4400	37.6	37.6	117	
	24	590	4000	4300	4400	4800	3100	3400	4000	4300	4600	4900	44.5	44.5	110	
	24	700	4300	4700	4800	5200	3400	3700	4300	4700	5000	5400	53.5	53.5	101	
	32	200	1800	1900	2000	2100	1400	1500	1800	1900	2000	2200	20	20	110	
	32	300	2900	3200	3300	3500	2300	2500	2900	3200	3400	3700	29.6	29.6	125	
	32	450	4400	4700	4900	5200	3400	3700	4400	4700	5000	5400	45.5	45.5	119	
	32	500	4700	5100	5300	5700	3700	4000	4700	5100	5400	5900	50	50	118	
	32	600	5300	5800	6000	6400	4200	4600	5300	5800	6200	6600	60	60	110	
	32	700	5800	6200	6400	6900	4600	4900	5800	6200	6600	7200	70	70	103	
	32	800	6000	6500	6700	7200	4700	5100	6000	6500	6900	7500	80	80	94	
48	200	2700	2900	3000	3200	2100	2300	2700	2900	3100	3300	28.9	28.9	114		
48	300	4400	4800	4900	5300	3500	3800	4400	4800	5100	5500	43	43	128		
48	400	5900	6400	6600	7100	4700	5000	5900	6400	6800	7400	57.5	57.5	129		
48	550	7600	8200	8500	9100	6000	6500	7600	8200	8800	9500	80	80	119		

Tolerance on LED flux is ± 7% and on total luminaire power ± 5 %

